

MODEL MW600

WELD-ON SADDLE FLOWMETER

DESCRIPTION

Model MW600 Weld-On Saddle Meter is machined to the same radius as the tube on which it is to be installed to provide accurate alignment. The Model MW600 is manufactured to comply with applicable provisions of American Water Works Association Standard No. C704-02 for propeller-type flowmeters. As with all McCrometer propeller flowmeters, standard features include a magnetically coupled drive, instantaneous flowrate indicator and straight reading, six-digit totalizer.

Impellers are manufactured of high-impact plastic, capable of retaining their shape and accuracy over the life of the meter. Each impeller is individually calibrated at the factory to accommodate the use of any standard McCrometer register, and since no change gears are used, the MW600 can be field-serviced without the need for factory recalibration. Factory lubricated, stainless steel bearings are used to support the impeller shaft. The shielded bearing design limits the entry of materials and fluids into

the bearing chamber providing maximum bearing protection.

The instantaneous flowrate indicator is standard and available in gallons per minute, cubic feet per second, liters per second and other units. The register is driven by a flexible steel cable encased within a protective vinyl liner. The register housing protects both the register and cable drive system from moisture while allowing clear reading of the flowrate indicator and totalizer.

INSTALLATION

Standard installation is horizontal mount. If the meter is to be mounted in the vertical position, please advise the factory. A straight run of full pipe the length of ten pipe diameters upstream and two diameters downstream of the meter is recommended for meters without straightening vanes. Meters with optional straightening vanes require at least five pipe diameters upstream and two diameters downstream of the meter.



The McCrometer Propeller flowmeter comes with a standard instantaneous flowrate indicator and straight-reading totalizer. An optional FlowCom register is also available.
Typical face plates.



APPLICATIONS

The McCrometer propeller meter is the most widely used flowmeter for municipal and wastewater treatment applications as well as agricultural and turf irrigation measurement. Typical applications include:

- Water and wastewater management
- Center pivot systems
- Sprinkler irrigation systems
- Drip irrigation systems
- Golf course and park water management
- Gravity turnouts for underground pipelines
- Commercial nurseries

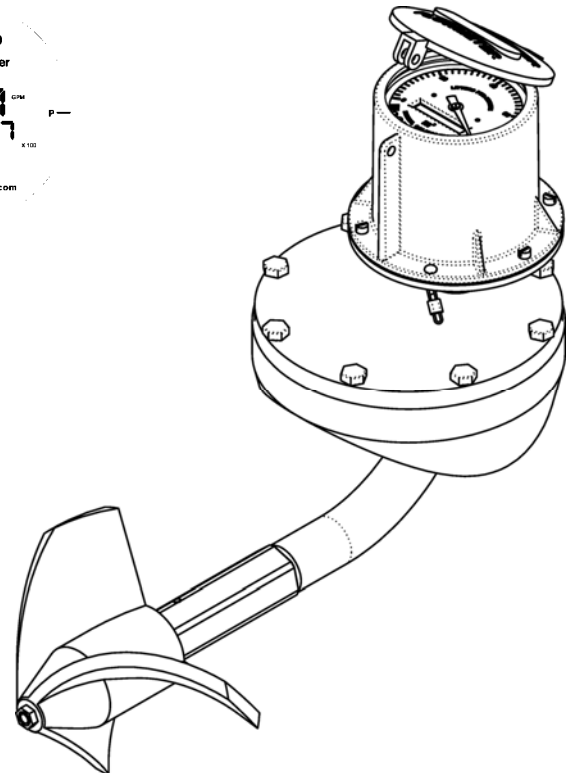

WELD-ON SADDLE FLOWMETER MODEL MW600

SPECIFICATIONS

PERFORMANCE

ACCURACY/REPEATABILITY: ±2% of reading guaranteed throughout full range. ±1% over reduced range.

Repeatability 0.25% or better

RANGE: see dimensions chart below

HEAD LOSS: see dimensions chart below

MAXIMUM TEMPERATURE: (Standard Construction)
160°F constant

PRESSURE RATING: 150 psi. Consult factory for higher rated version.

MATERIALS

SADDLE: Carbon steel

TOP PLATE: Fusion-bonded exoxy

BEARING ASSEMBLY: Impeller shaft is 316 stainless steel.
Ball bearings are 440C stainless steel.

MAGNETS: Permanent type. Alnico.

BEARING HOUSING: Brass; 316 stainless steel
Optional

REGISTER: An instantaneous flowrate indicator and six-digit straight-reading totalizer are standard. The register is hermetically sealed within a die cast aluminum case. This protective housing includes a domed acrylic lens and hinged lens cover with locking hasp.

IMPELLER: Impellers are manufactured of high-impact plastic, retaining their shape and accuracy over the life of the meter. High temperature impeller is optional.

OPTIONS

Weld-on saddle can be profiled to fit any outside diameter pipe dimensions

Forward/reverse flow measurement

Register extensions

All stainless steel construction

High temperature construction

“Over Run” bearing assembly for higher than normal flowrates

Electronic propeller meter available in all sizes of this model

A complete line of flow recording/control instrumentation

Certified calibration test results

Stainless steel bearing housing

Canopy boot

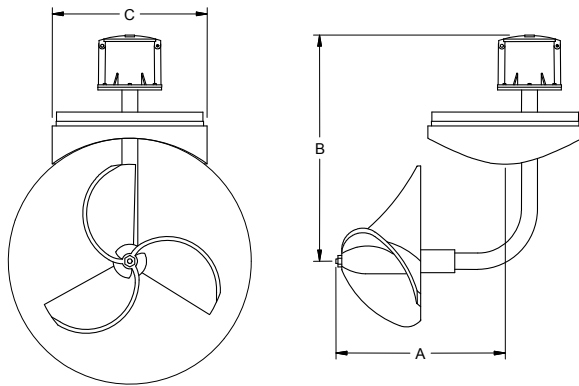

MW600	DIMENSIONS													
Meter Size (inches)	4	6	8	10	12	14	16	18	20	24	30	36	42	48
Maximum Flow U.S. GPM	600	1200	1500	1800	2500	3000	4000	5000	6000	8500	12500	17000	25000	30000
Minimum Flow U.S. GPM	50	90	100	125	150	250	275	400	475	700	1200	1500	2000	2500
Standard Dial Face (GPM/Gal)	800/ 100	1300/ 100	2500/ 100	3000/ 1000	4000/ 1000	6000/ 1000	8000/ 1000	10000/ 1000	10000/ 10000	15000/ 10000	15000/ 10000	30000/ 10000	35000/ 10000	**
Approx. Head Loss in Inches at Max. Flow	23.0	17.0	6.75	3.75	2.75	2.00	1.75	1.50	1.25	1.00	.7	.5	.45	.3
Approx. Shipping Weight-lbs.	30	45	70	90	120	125	130	150	175	190	205	210	220	230
A (inches)	11.37	12.87	12.87	12.12	12.12	12.12	12.12	15.00	15.00	15.00	15.00	15.00	15.00	15.00
B (inches)	10.75	10.75	11.75	13.75	14.75	14.75	16.75	16.75	18.75	20.75	22.38	26.38	29.38	32.38
C* (inches)	5 ½	7 ½	7 ½	10 ¾	10 ¾	10 ¾	10 ¾	12 ¾	12 ¾	12 ¾	18	20	20	20
No. of Topplate Bolts	6	8	8	12	12	12	12	16	16	16	16	16	Contact	Factory

* Dimension C is O.D. of saddle.

** Per customer requirements

Larger flowmeters on special order.

To order:

Specify pipe I.D. and O.D.

The pipe O.D. determines the meter size.

The model number is established by taking the pipe O.D. to the next larger size.

For example, a 14" cast iron pipe with a 15.3" O.D. would be a 16" meter, or a model 'MW616.'

REPRESENTED BY:

TechnoFlo Your Flow Meter Source

PO Box 1448 Porterville, CA 93258

• 559-783-1207